



Studies of a PIP-II Mu2e Experiment

Mary Anne Cummings

Muons, Inc.

NAPAC 2022

Albuquerque, NM.



What is Muons, Inc.?

- Founded 2002, subsidiaries - MuPlus, MuSTAR - by Scientists from US National Labs – original mission to design a **Muon Collider**
- **Mu*STAR** Accelerator-Driven Subcritical molten-salt nuclear Reactors
 - Major focus of our companies
- NEW tools and technology for particle accelerators – One example, the Helical Cooling Channel (HHC) concept.
- Funded by DOE (and DOD) contracts and SBIR-STTR grants total of ~\$36M
- 11 US university and 11 national lab research partners
 - Broad, diverse and cutting edge scientific network
 - We are embedded in both worlds
- Supported 18 post-docs and 6 Ph.D. students
- Software products:
 - G4beamline - interface to GEANT4, optics and tracking
 - MuSim - interface to several codes, optics and tracking



G4Beamline

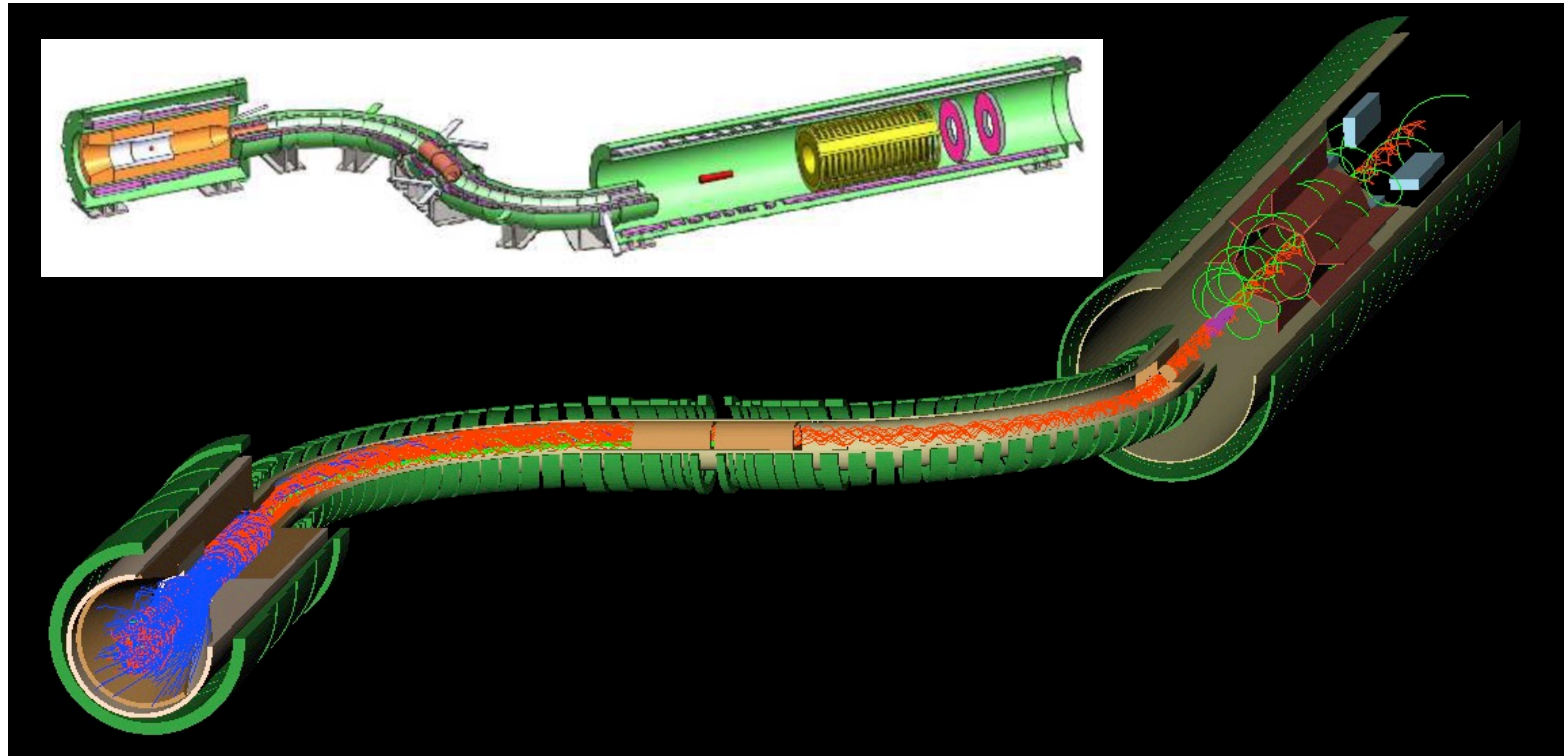

Simulation of the Mu2e beam channel and detector as an example of use of the G4beamline interface to Geant4. Simulations of complex magnet channels, acceleration fields and tracking of particles through these fields.

Both through matter and vacuum - can be done without knowledge of C++ !!



PIP II: FNAL Intensity Upgrade for Mu2e

- The current Mu2e design is optimized for 8 kW of protons at 8 GeV.
- The proposed PIP-II upgrade project is a 250-meter-long CW linac capable of accelerating a 2 mA proton beam to a kinetic energy of 800 MeV (total power 1.6 MW)
- In 2016, Muons, Inc. looked at finding an accommodation to the future Fermilab program with as little change to the **current Mu2e** experimental setup and beamlines as possible. Considerations included:
 1. Appropriate proton beam time structures,
 2. Proton beam transport,
 3. Production of mu-,
 4. Transport of mu- into the detector and stopping target,
 5. Heating and irradiation of magnet coils,
 6. Veto rates,
 7. Acceptable live times,
 8. Stopping rates, and
 9. Backgrounds.



Muons, Inc. Previous Mu2e-II Study

First observation: 800 MeV protons have **1/10** the kinetic energy of 8 GeV protons, they have **1/6** the momentum. Scaling all magnet currents by 1/6:

1. PIP-II beam follow the same trajectory through the production solenoid, missing the heat and radiation shield (HRS), and hitting the beam absorber.
2. But this would give the transport solenoid too small a field to transport most of the muons, and would give the detector too small a field for the detector to work at all.

So the simple and obvious approach does not work.

Muons, Inc. did initial studies of Mu2e in the PIP-II era, looking at three scenarios:

1. No changes (except magnet currents and re-alignments)
2. Minimal changes (leave all coils alone)
 - Modifying the HRS with a new beam hole
3. “Modest” changes
 - Remove one TS coil
 - Modest changes to HRS, target, and beam absorber



Backward Production #1 and #2

- The first scenario attempted to put 800 MeV protons onto the Mu2e production target, using the same hole in the HRS as the 8 GeV beam. We found that while it is possible to hit the target, it is not possible for the beam to miss the HRS. The HRS (obviously) cannot handle the full 100 kW beam. The production solenoid field was varied from 3 T to 5 T (baseline, 4.5 T), but it is not possible to use 800 MeV protons with the current HRS, production solenoid, and target.
- The second scenario considered drilling a new beam hole into the HRS, and moving the beamline ahead of the HRS to match. By moving the incoming proton beam closer to the production solenoid axis, it is possible to hit the target and miss the HRS. But this was found unacceptable for three reasons:
 1. The brass HRS was found to be inadequate to protect the production solenoid coils from 100 kW of beam.
 2. It is unlikely that holes could be drilled, as the HRS will be highly **radioactive** after Mu2e operation. (Mu2e design and fabrication were too advanced to consider doing this before operation starts.)
 3. One or more transport solenoid coils were always in the way.

Backward production #3

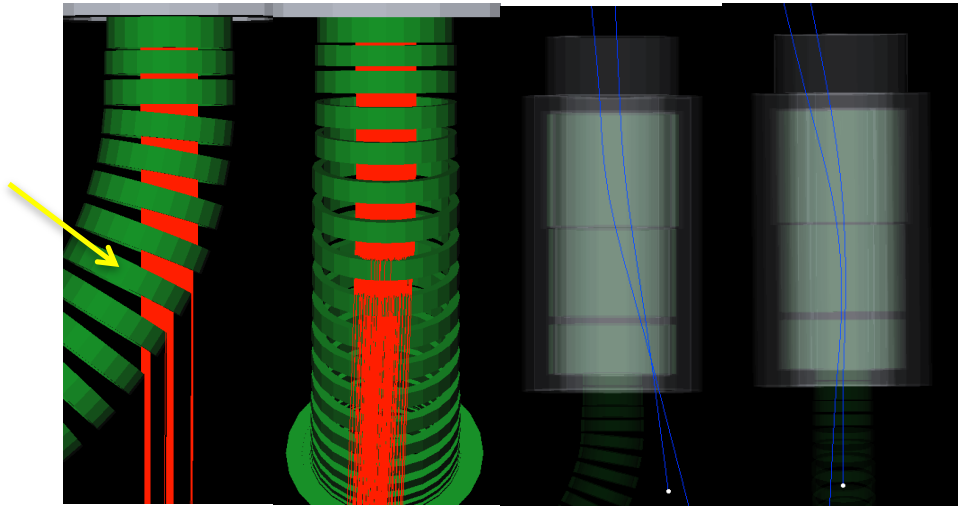

Side and top views of coils in the transport solenoid, with 800 MeV protons from the target tracked *backwards* (headed downward) to show where they intersect the transport solenoid. The yellow arrow points to the TS coil that would be removed (left). This moves the beam in the production solenoid (right).

So the “modest change” approach would require:

1. Removing one TS coil and drilling a hole for the beam in its cryostat.
2. Replace the HRS with one made of tungsten.
3. Move the beamline ~100 mm closer to the TS, slight angle.
4. Move the target, add active cooling.
5. Move the beam dump.

This is not really a “modest change”.



Forward Production Mu2e-II

- The conclusion of this earlier work was that for Mu2e in the PIP-II era, using the 800 MeV beam requires a **redesign** of the beamline, target, HRS, production solenoid, and beam absorber. Which makes a **complete change of concept** a reasonable alternative.
- Muon-collider front ends generate significantly more muons per proton than Mu2e's target and production solenoid. ($.06 \mu/p$ vs $.0016 \mu/p$)
- Mu2e rejected such forward production due to the muon background it generates.
- Mu2e-II has an easier solution fo muon background: 2 meters of concrete will range out 800 MeV muons.
- Mu2e-II 800 MeV beam will not produce anti-protons!
- The Muons, Inc. ionization cooling technology has been successfully demonstrated! (elements of the Helical Cooling Channel).



Forward Production Features

- A small amount of **longitudinal cooling** can significantly increase the fraction of muons that stop.
- The absorber used for cooling can significantly clean up the hadron flash. This might permit a shorter dead time and allow the use of higher-Z stopping targets.
- Muon collider front ends considered much higher beam power and ignored backgrounds; this needs to be looked at from a Mu2e-II perspective... part of Muons, Inc. proposal
- Muons, Inc. had two SBIR projects that are directly related:
 - Stopping Muon Beams
 - Isochronous Muon Beams
- Neuffer, Bao, and Hansen did a related study.
- There is potentially a lot to be gained here; the challenge is to keep it affordable and re-use as much of Mu2e as possible.

Particle Motion in a Helical Magnet

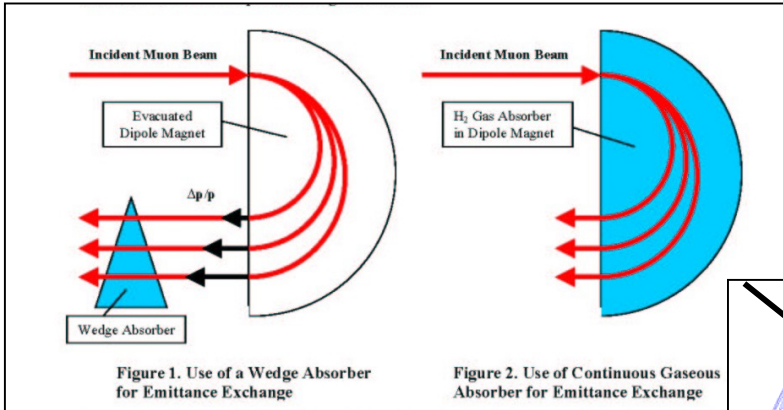

Dipole → Dipole + Solenoid (+Quad for stability)

$$\left. \begin{aligned} F_{h-dipole} &\approx p_z \times B_{\perp}; & b &\equiv B_{\perp} \\ F_{solenoid} &\approx -p_{\perp} \times B_z; & B &\equiv B_z \end{aligned} \right\} f_{central} = \frac{e}{m} (b_{\phi} \cdot p_z - b_z \cdot p_{\phi})$$

Transforming to the frame of the rotating helical dipole leads to a time and z –independent Hamiltonian, can form relation:

$$p(a) = \frac{\sqrt{1 + \kappa^2}}{k} \left[B - \frac{1 + \kappa^2}{\kappa} b \right]$$

Manipulate values of parameters to change performance

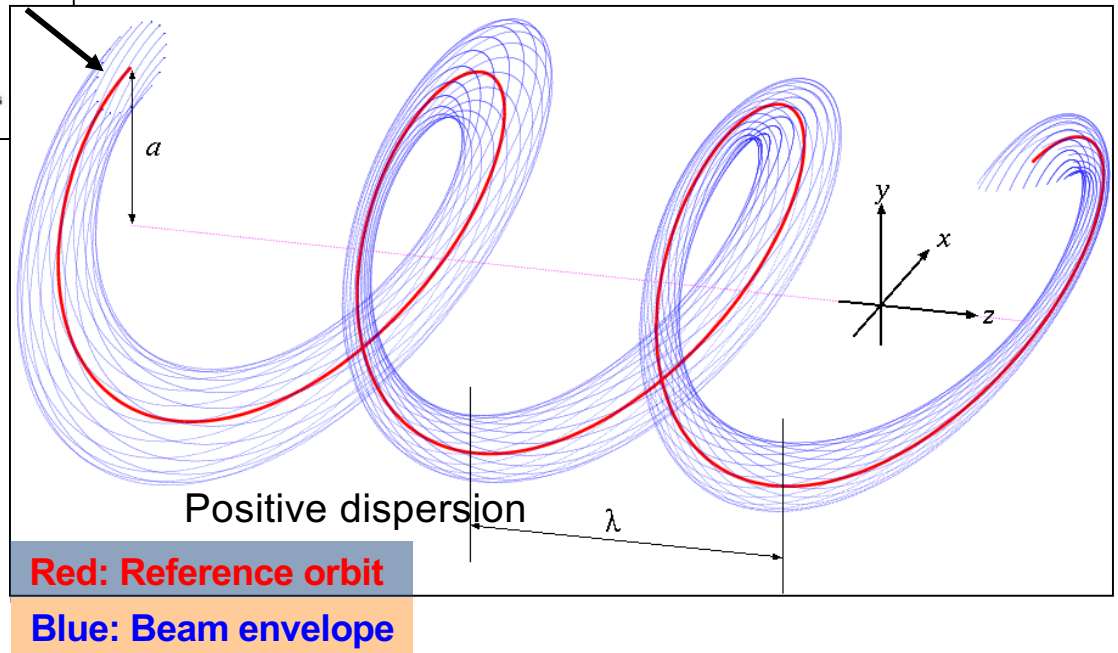

Dispersive component makes longer path length for higher momentum particles and shorter path length for lower momentum particles.



HCC Elements for muon production

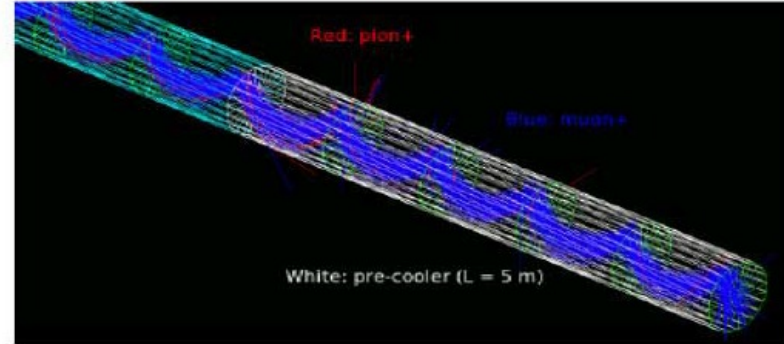
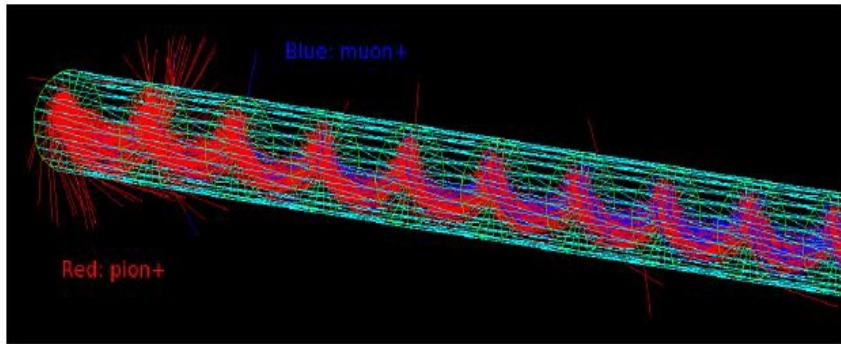

G4Beamline simulation of muon (blue) and pion (red) orbits in a HCC-type magnet that is adapted as a decay channel (right).

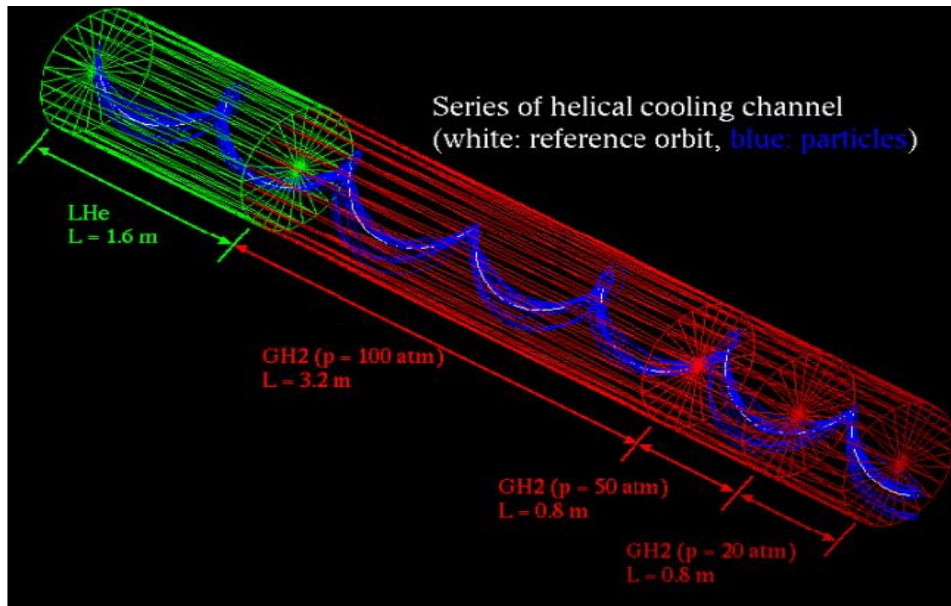

Helical Cooling Channel (HCC)

Higher-momentum particles lose more energy because they have longer path lengths in the gaseous absorber, thereby reducing the beam energy spread and hence the longitudinal emittance.

Intense Stopping Muon Beams

STTR DE-FG02-07ER84824 “Stopping Muon Beams” (2007-2009)

Dipole and Wedge
Into HCC

Matching into the HCC
which degrades muons
to stop in target

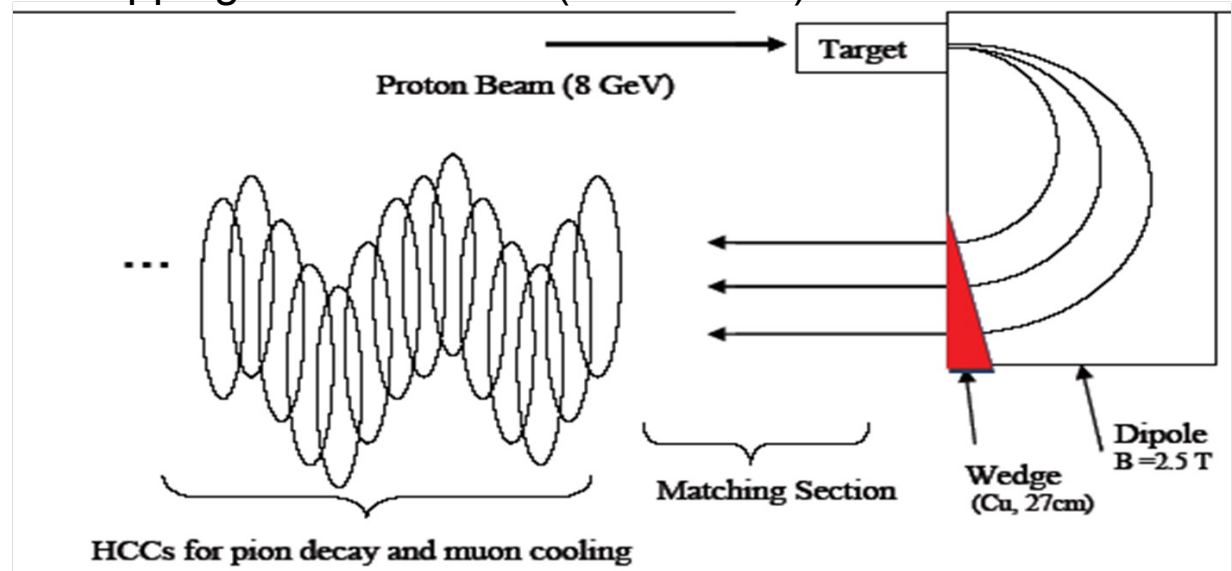

180° dipole bend removes large
neutral backgrounds.

Muons with a narrow time and
momentum spreads will enable
the use of higher Z target, and
maintain the necessary
“extinction” factor.

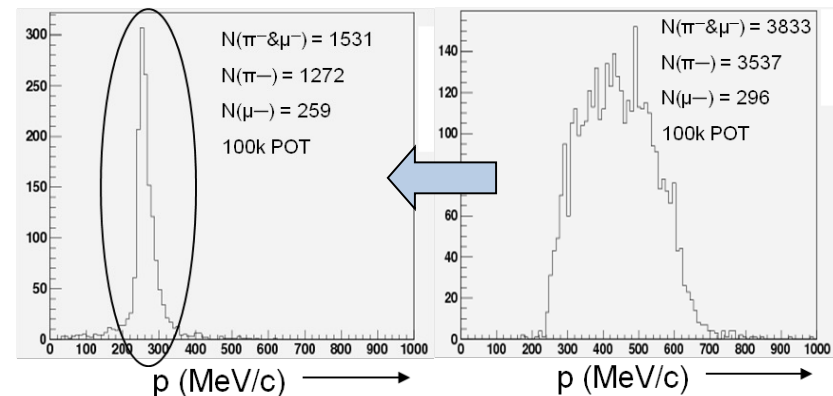

Wedge narrows P distribution

Stopping Muon Beams for Mu2e

Using an HCC to reduce the energy spread of the secondary pion beam which produces the muons, decrease backgrounds and increase mu/p production.

μ/p production can be optimised by capturing pions at the production peak. Cooling brings down the mean momentum low enough to stop in the detector target.

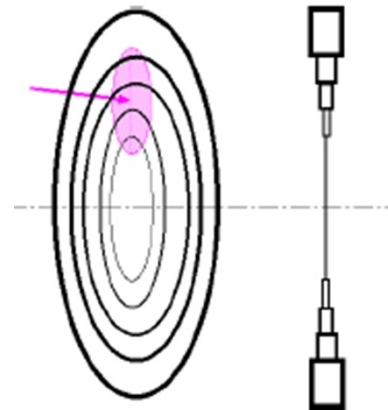
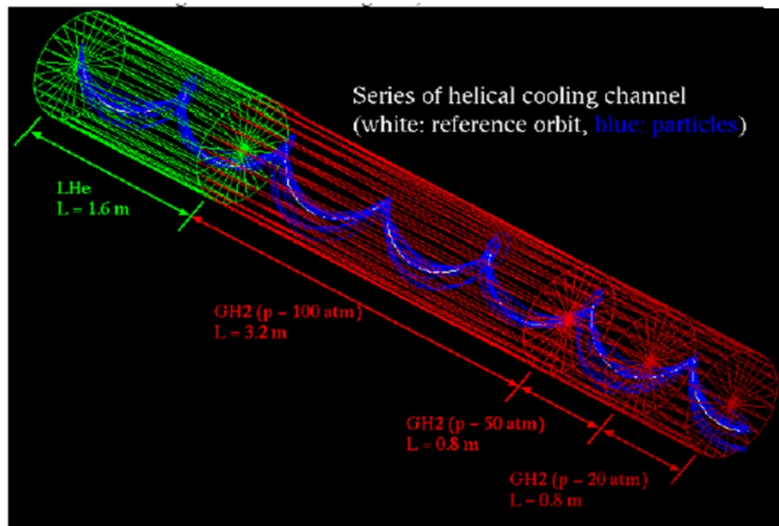
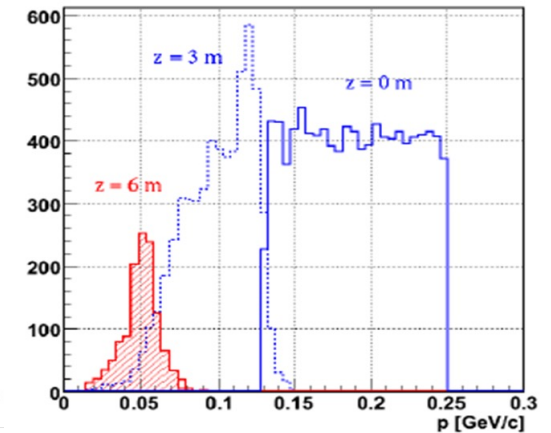
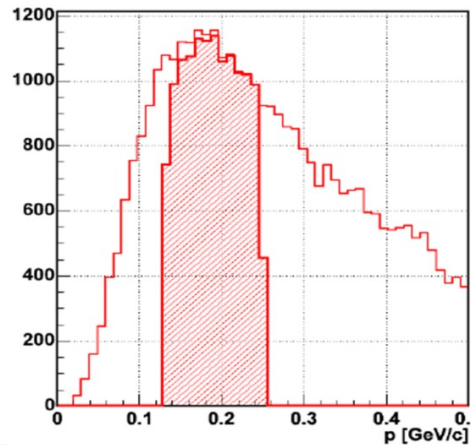

“Tapered-density” absorber HCC channel: “concept” study (1), and a element of a realistic absorber (2), a thin radial LiH wedge. Density is decreased by increased wedge spacing.

Quasi-Isochronous Helical Channel

STTR DE-SC0002739 “Quasi-Isochronous Muon Collection” (2009-2011)

Another HCC, a Quasi-Isochronous Helical Channel (QIHC) to facilitate capture of **muons into RF buckets**, has been developed further. The resulting distribution could be cooled quickly and coalesced into a single bunch to optimize the luminosity of a muon collider. It also can be optimized for Mu2e

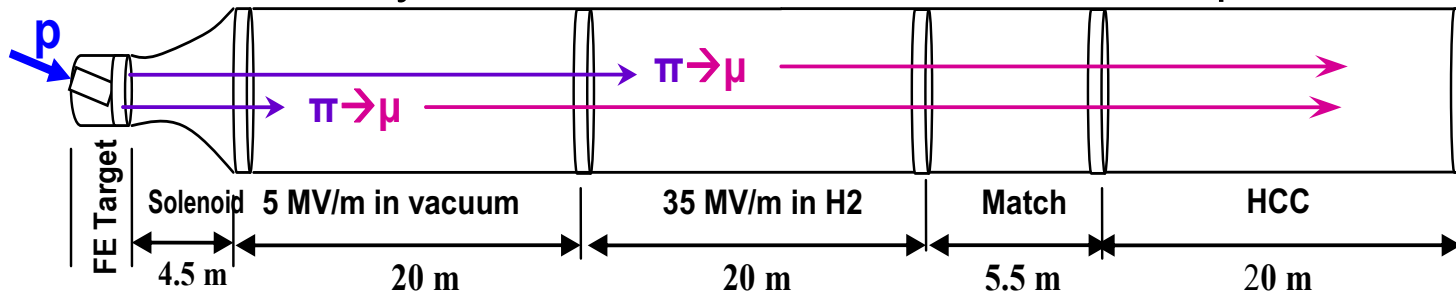

- (1) A helical magnetic field that creates helical particle trajectories near a reference orbit of a selected muon momentum
- (2) RF cavities that capture particles in stable buckets, and
- (3) An absorber that reduces the energy of particles that would otherwise be too energetic to be captured.

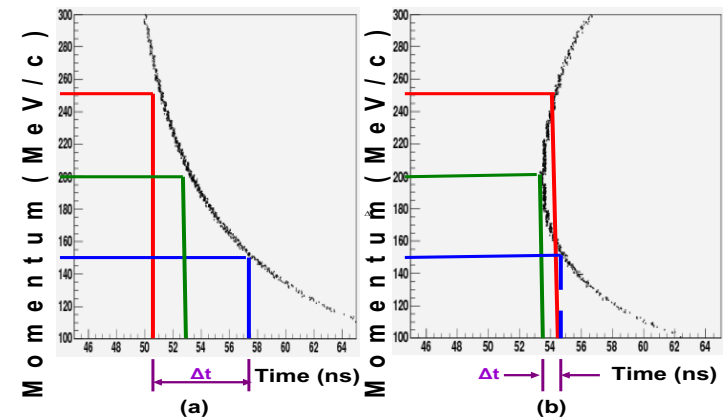



Muons,
Inc.

Low Energy Production of Bright Muon Beams

- The Muons, Inc. inventions were based on 8 GeV proton sources. This will have to be studied for the 800 MeV proton source. The efficiencies at lower momenta will have to be studied and other or additional schemes will be examined. **Starting here:**
 - The collection $\pi \Rightarrow \mu$ at $\sim 70\text{--}200$ MeV/c
 - The efficiency of energy-loss absorption could be improved by introducing dispersion and **adding a wedge** component so that higher-energy muons pass through more material.
 - Deceleration can be considered
 - **Dave Neuffer** et al have developed a low energy capture model that feed into a decelerator: ($\sim 0.04 \mu/p$)

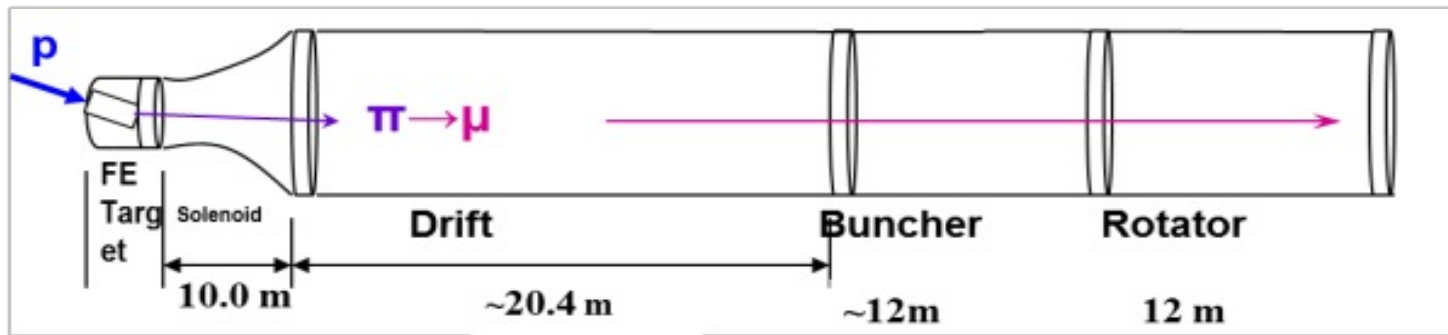



Snowmass 2022 on muon colliders

Physics & technology landscape has significantly changed since 2013

- Explosion of interest in muon colliders as indicated by the number of publications, activities in IMCC, Muon Forum etc
- Outstanding physics program
- Minimum muon collider accelerator and detector requirements are within reach or technologically available

There has been a recent considerable growth of interest about MuC from the particle physics community:

- Significant growth of related publications & related workshops
- Formation of the IMCC

We are asking Snowmass/ P5 to support a MuC program in the US

- Enable collaboration with IMCC, provide funding for R&D
- Further develop the site-filler concept for the next Snowmass process

This is scenario where forward μ production of a PIP-II Mu2e would be highly compatible!

Closing Thoughts

- Direct $\mu \Rightarrow e$ conversion would be the “golden channel” of charged lepton flavor violation (CLFV). CLFV would probe a complementary area of New Physics from that of the rest of the High Energy Physics Program, definitely worth a serious PIP-II era effort.
- Adapting to the PIP-II era will require substantial changes to the current Mu2e experiment – a forward production scheme is not unreasonable as a viable alternative, and offers:
 - The ability to change stopping targets
 - Maintain high background suppression
- In a US HEP program that includes significant muon collider R&D, a forward production Mu2e configuration would have significant synergies, technically and programmatically!



Muons Inc. Proposed Study (not funded)

- At present (2019, 2021?), PIP-II has not been fully defined, but its basic structure as an 800 MeV H⁻ linac is not expected to change:
 - **Intensity studies:** PIP-II linac will be capable of accelerating a continuous beam, initially it will have fewer power supplies and only accelerate a pulsed beam with ~ 10% duty factor could have a significant impact on the time structure and overall intensity available for the Mu2e-II beam.
 - **Beam stripping:** As PIP-II will accelerate an H⁻ beam, it might be possible to use the stripping of H⁻ to protons to improve the extinction of the proton beam between desired pulses on the production target. or using laser stripping with the laser off between desired bunches or H⁰ (Dr. Roberts)
- **Forward production:** In previous grants Muons, Inc. applied new **six-dimensional beam cooling inventions** for muons colliders, improved capture techniques, and our new simulation tools to develop designs for low-energy beam lines to stop many muons in small volumes.
 - STTR DE-FG02-07ER84824 “Stopping Muon Beams” (2007-2009)
 - STTR DE-SC0002739 “Quasi-Isochronous Muon Collection” (2009-2011)



Muons, Inc. DOE Mu2e-II Proposal

- **Task 1. The general relationship between PIP-II and Mu2e-II**
 - 1a. H- beam energy and time structure
 - 1b. Stripping H⁻ to protons
 - 1c. Overall intensity
 - 1d. Extinction of beam between desired pulses
 - 1e. Accommodating PIP-II design revisions as they happen
- **Task 2. Backward Muon Production (as in current Mu2e)**
 - 2a. Preliminary design of a new production solenoid, target, and heat and radiation shield (HRS)
 - 2b. Considerations of target and HRS cooling
 - 2c. Preliminary design of proton beam transport into the target, and to the beam absorber
 - 2d. Evaluation of changes required to the transport solenoid
 - 2e. Optimization and evaluation of the overall stopping muon rate
 - 2f. Consider stripping to H⁰ immediately before the production solenoid
- **Task 3. Forward Muon Production (muon collider / neutrino factory)**
 - 3a. Develop several forward-production concepts
 - 3b. Analyze concepts, optimizing stopping mu- rate, cost, and overall size and layout
 - 3c. Select one concept for presentation
 - 3d. Consider how to place components in the Fermilab muon campus
 - 3e. Optimization and evaluation of the overall stopping muon rate

Some Important HCC Relationships

Hamiltonian Solution $p(a) = \frac{\sqrt{1+\kappa^2}}{k} \left[B - \frac{1+\kappa^2}{\kappa} b \right]$ $k = 2\pi/\lambda$ $\kappa = ka$

Equal cooling decrements $q \equiv \frac{k_c}{k} - 1 = \beta \sqrt{\frac{1+\kappa^2}{3-\beta^2}}$ $k_c = B\sqrt{1+\kappa^2}/p$

Longitudinal cooling only $\hat{D} \equiv \frac{p}{a} \frac{da}{dp} = 2 \frac{1+\kappa^2}{\kappa^2}$ $q = 0$

~Momentum slip factor $\eta = \frac{d}{d\gamma} \frac{\sqrt{1+\kappa^2}}{\beta} = \frac{\sqrt{1+\kappa^2}}{\gamma\beta^3} \left(\frac{\kappa^2}{1+\kappa^2} \hat{D} - \frac{1}{\gamma^2} \right)$ $\frac{\kappa^2}{1+\kappa^2} \hat{D} \sim \frac{1}{\gamma_{transition}^2}$